

Euler equations perfect fluid

configuration variables
inner space orientation
intervals instants

source variables
outer space orientation
instants intervals

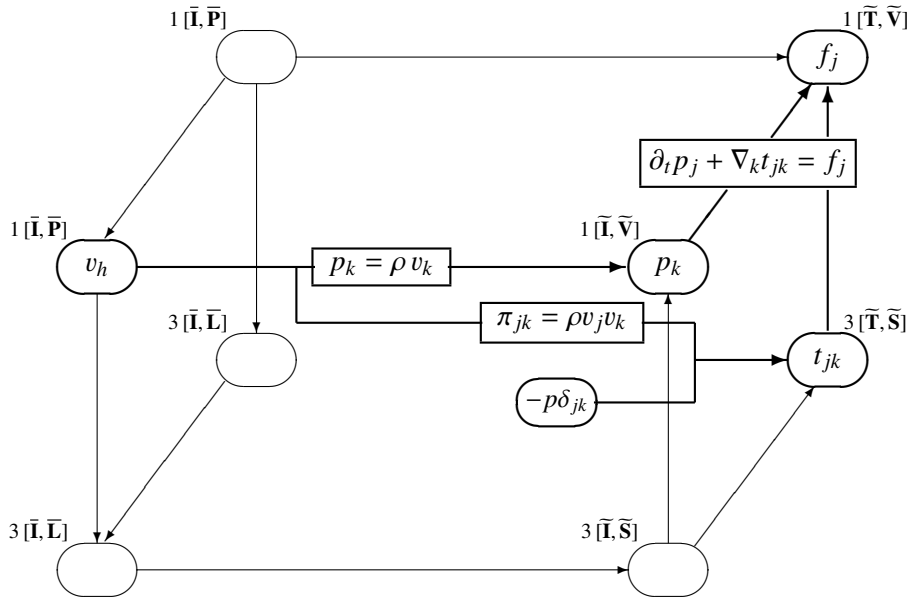

$$\partial_t (\rho v_j) + \nabla_k (\rho v_j v_k + p \delta_{jk}) = f_j$$

$$\partial_t (\rho v_j) + \nabla_k (\rho v_j v_k) = f_j - \partial_j p$$

$$t_{jk} = \pi_{jk} + p \delta_{jk}$$

- v_h velocity
- f_j volume force density
- p_k momentum density
- t_{ik} total stress tensor
- π_{jk} dynamical stress tensor
- ρ mass density

